

ULTRABLOCK, INC.

Manufacturer of LOCK-BLOCK®

Retaining Wall Systems

815 N.E. 172nd Ave Vancouver, WA. 98684

360-694-0141 Office * 800-377-3877 Toll Free * 360-694-0281 Fax

www.ultrablock.com

FIELD CONSTRUCTION MANUAL - GRAVITY

EXCAVATION

Confirm location and elevation of walls. Width of excavation should allow for width of wall base and drainpipe. Note: all excavation should follow OSHA guidelines. If the wall steps up one block in height, the base should be installed at the lowest level in order to establish grade and face location of the second level.

BASE PREPARATION

Consult engineer's wall design for base material specification including type, width, depth and compaction. It is recommended to start at the lowest wall level. Locate the front face of the wall and run a string line one (1) inch in front of the face-- two (2) inches above the base.

Use 2x6 or 2x8 pieces of wood, with 18" steel stakes nailed to each end, for forming up the base (See Diagram 1).

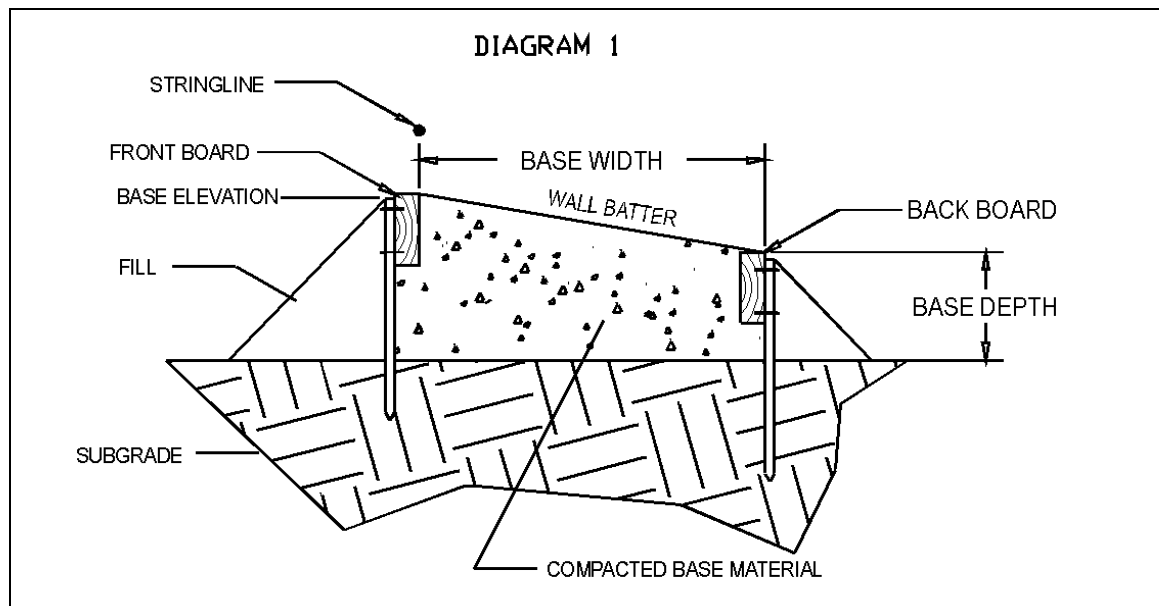

Set front board in line with string and at base elevation of wall. Locate the back board at the base width (of wall) distance from the front board. Set elevation of back board to give the proper wall batter. For example, if the wall has a 6:1 batter, and the base of the wall is 30 inches wide (2.5 ft) then the back board should be five (5) inches lower than the front board (See DIAGRAM 2).

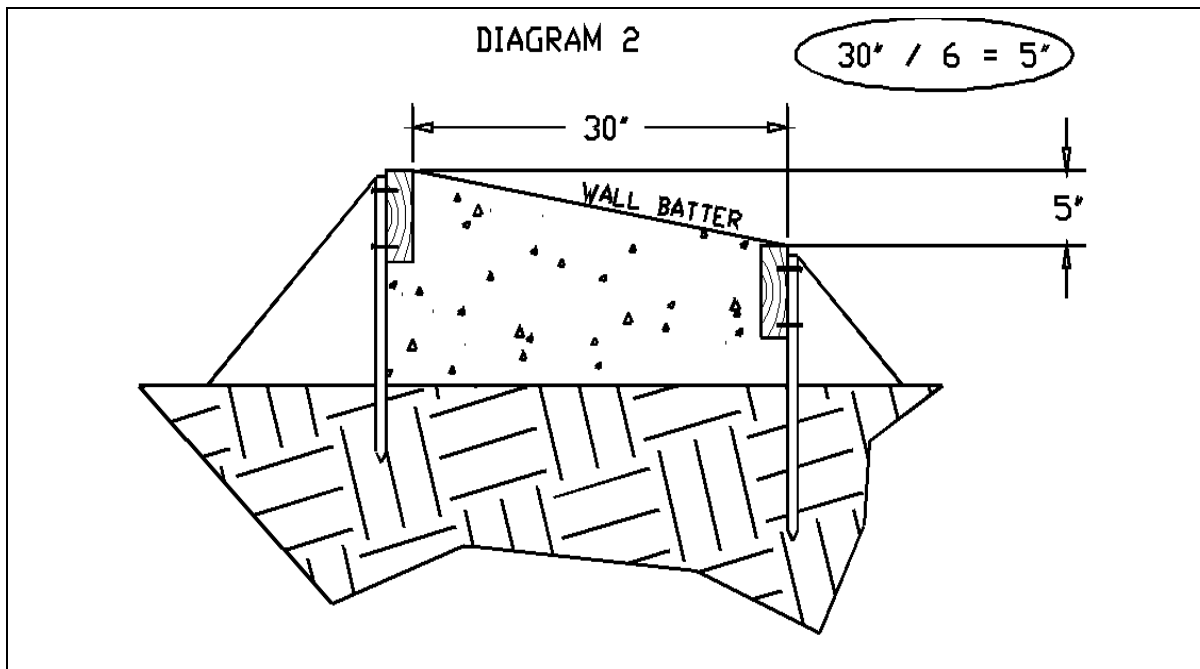

Make sure the base material is well compacted. Test if necessary. Be careful not to push out boards during compaction. After compacting, screed off base material, fill in low spots, and screed again. Repeat procedure as necessary to achieve firm, compacted base.

Without moving the string line, start leap-frogging the base boards further on down the wall line and continue preparing the base. Do not disturb string line. It is best to prepare the entire base before setting the blocks.

CURVED WALLS BASE PREPARATION

Curved walls require many more location points to define the curve (the tighter the curve, the more location points). Use bender boards to the back width and batter the wall. Fill, compact and screed base material as required.

SETTING BLOCKS

Before placing blocks, make sure the top and bottom surfaces of the respective blocks are clean. At one end of the wall, or at one end of the lowest base elevation, start the wall. At the start of the wall, mark a line perpendicular to the face of the wall. This line will help place the first block square to the wall face. Place the first block one inch from the string line. Set the next block beside the first block, taking care to align the face. If the base width of the wall requires 2 or more blocks, place the blocks at the back of the wall first (it may help to run a temporary string line). Always place best face of the blocks on the outside of the wall (See DIAGRAM 3).

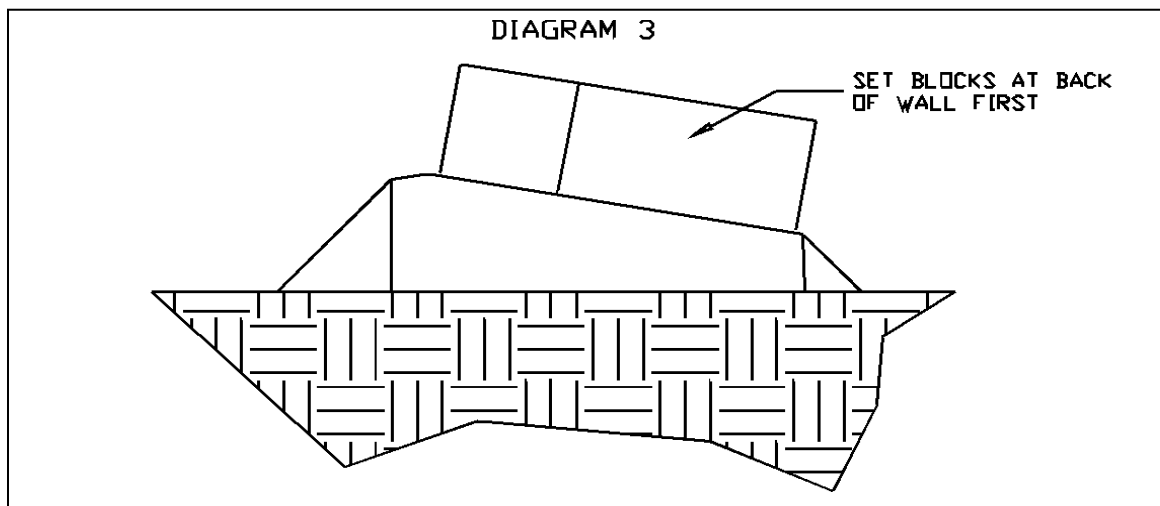

Do not set any more than 25 to 30 feet of blocks along the length of base before starting the second or third row. The block keyways have a limited amount of play, which could lead to binding if installed incorrectly.

Blocks are poured facedown with the side of the block form being open. This means that the width of blocks may vary and care must be taken when placing block side by side. It is always best when setting blocks in this configuration to measure from a point on one block to the same point on the adjacent block ensuring the dimension is within keyway tolerance. There is a half inch of mating tolerance around each key where the center of the tolerance is approximately 29.5" (See DIAGRAM 3A).

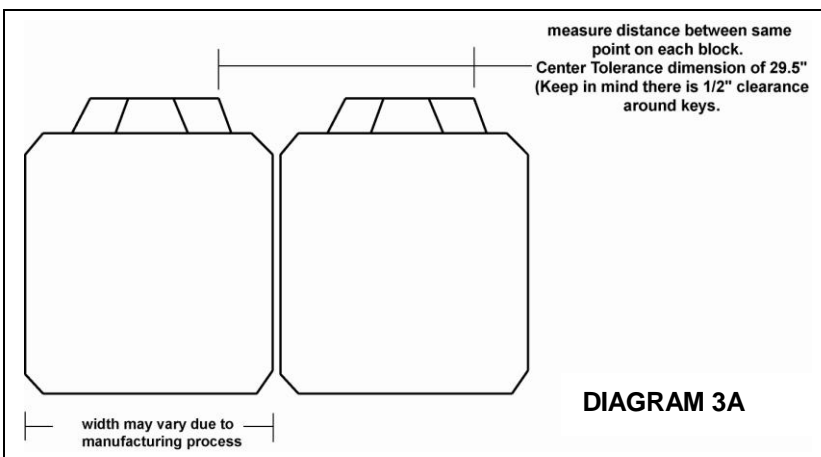

If binding does occur between the first and second row of blocks, leave a 1/4" gap when placing the next base block. Another suggestion to reduce the binding is as follows: When building the base going left to right, after placing each second row block, push the second row block right to left until it no longer slides along base block. Make sure the upper blocks do not slide up on the keys of lower row blocks (See DIAGRAM 4).

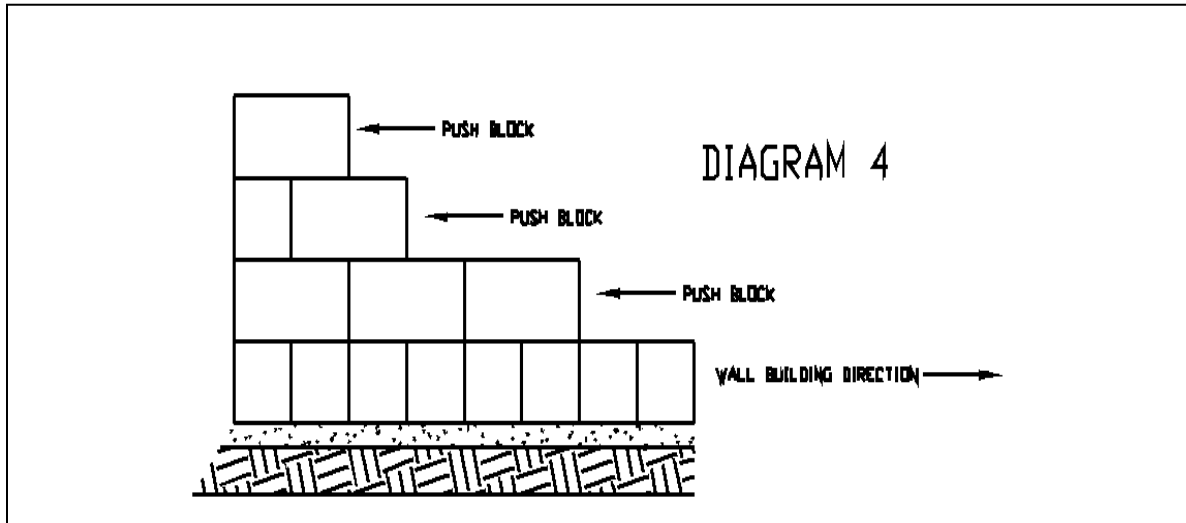

If building walls with geogrid, make sure geogrid is extended through to the front face of the block. Geogrid reinforced walls require that the backfill and geogrid be compacted and stretched as the wall goes up. Make sure drainpipe, filter fabric, and drain mats (if required) are installed before backfilling. Backfill material and compaction must meet engineer's requirements. Test as necessary. Continue placing blocks being careful to align the face.

EQUIPMENT FOR PLACING BLOCKS

A track mounted excavator is the ideal piece of equipment for setting blocks. A wire rigging with swivel hooks, OSHA approved and rated for the weight of the blocks, can be attached to the excavator and used for lifting and moving blocks.

SAFETY FACTORS

1. Never stand underneath a block
2. Never accept or install blocks with a cold joint (LEAVE ON DELIVERY TRUCK)
3. Avoid getting any part of the body between pinch points while installing blocks (either between two blocks or between a block and the open excavation).
4. Always inspect rigging for lifting the block. Replace all worn out or broken parts. **DO NOT USE INFERIOR, INADEQUATE OR UNAPPROVED EQUIPMENT.**

USEFUL TOOLS

1. Transit- to lay out a level base.
2. Shovels and rakes- for use by the base prep person.
3. A lifting jig- to hold the blocks at the correct batter.
4. A broom- to clean the keyways before placing the next layer.
5. One or more 5 foot pry bars- for jostling the blocks into position.

CORNERS

1. Vertical walls can be locked at 90 degree corners.
2. Battered walls at 90 degree corners are constructed as follows:
Stack a vertical column to fill the corner. Adjust top of battered wall to meet with corners of vertical stack (ie: kick toe out for outside corner, meet toe at edge for inside corner). For walls higher than 7.5', you may use a stack of full-size, interlocked blocks to make a 5x5' vertical stack, rather than 2 2.5x2.5' stacks with single half blocks (See below).

Use geogrid between the vertical blocks, extending back into the fill. Make the corner stack the same width as the wall base (2.5' / 5' / 7.5' ect)

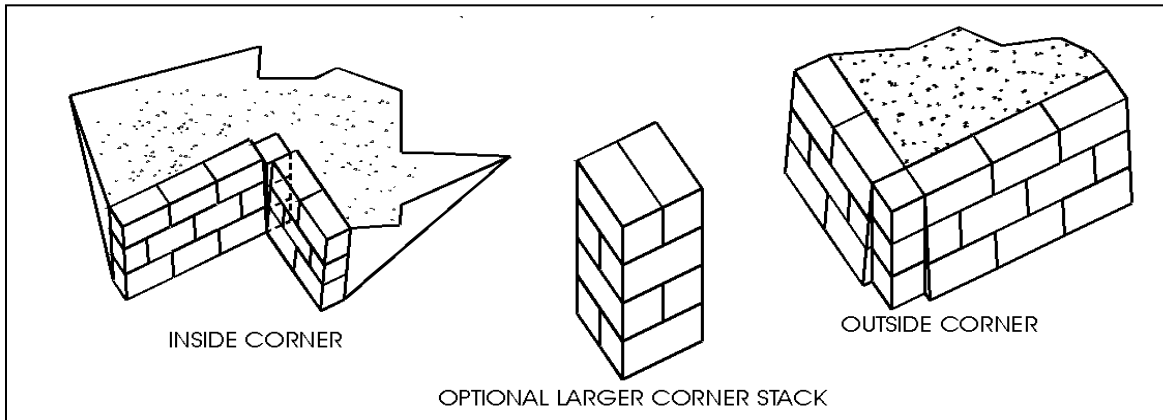

EXCAVATION

If the radius of the wall is less than the allowable radius then contact the manufacturer and see if arrangements can be made for special block.

WALL WIDTH	MINIMUM RADIUS OF CURVE
2.5	100'
5'	200'
7.5'	300'
10'	400'

FINAL LEVELING OF THE WALL

Imperfect or disturbed bases cause a wall to not run straight and level. It is recommended to shim (asphalt shingle) wall if necessary or place a 4x6 on top of the wall at the high points and pound down with the excavator bucket.